

ARTÍCULO

REFERENCIA C12 - CAJA EMPALMES 105x105x51 CON TORNILLOS

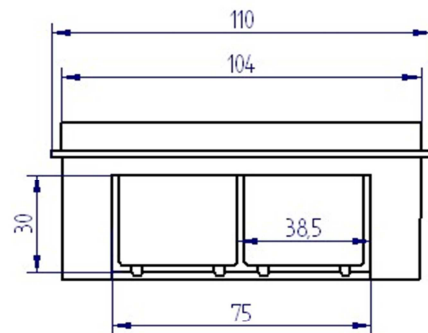

**C 12**

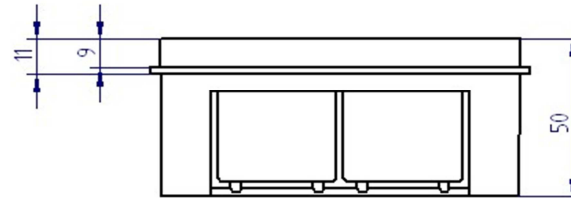
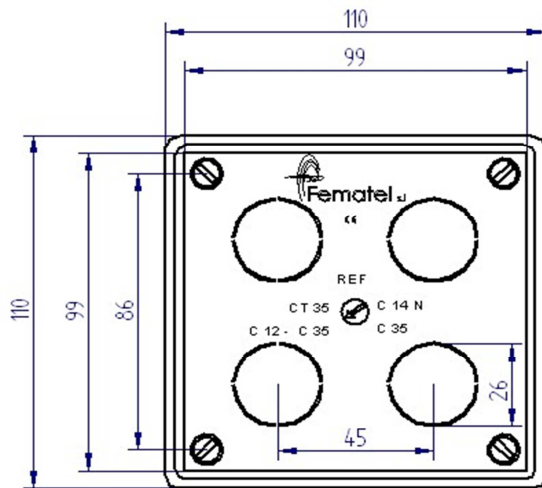

DATOS TÉCNICOS

Denominación: Caja de empalmes y derivación con tornillos.

Medidas: 105x105x51 mm.

Fabricado en material termoplástico libre de halógenos

Color caja : Negro

Color tapa: Blanco

Peso neto: 0,103 Kg.

Código EAN

MARCAS Y CERTIFICACIONES



